

DRACO D19 SL

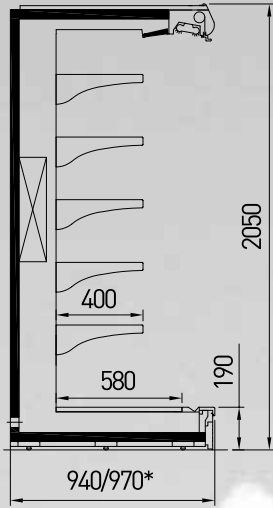

DRACO M19 SL

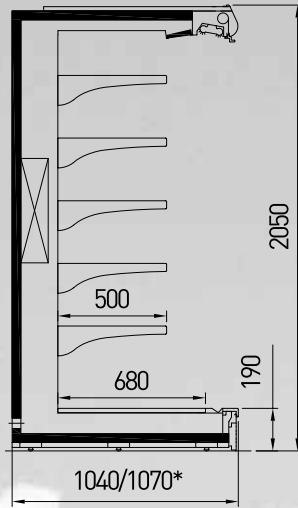

DRACO G19 SL

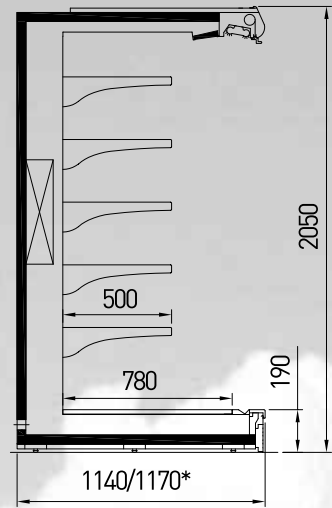

DRACO D29 SL

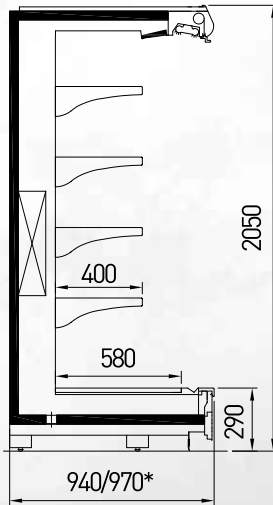

DRACO M29 SL

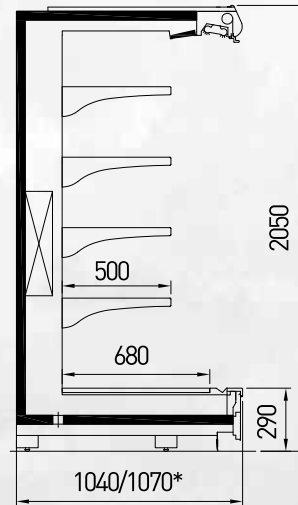

DRACO G29 SL

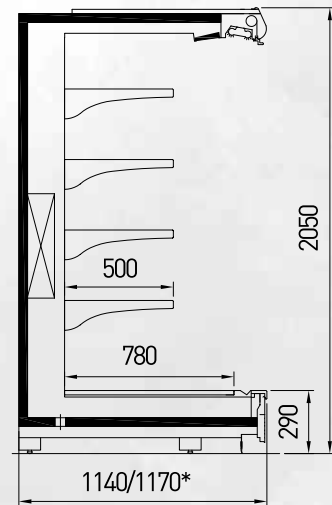

DRACO D41 SL

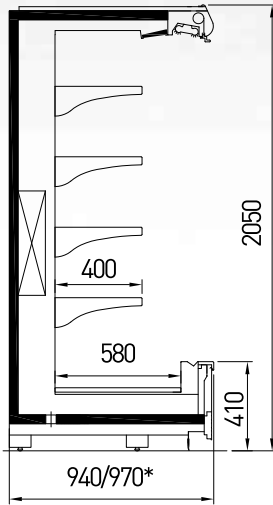

DRACO M41 SL

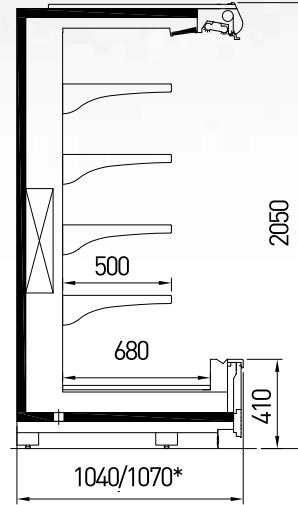

DRACO G41 SL

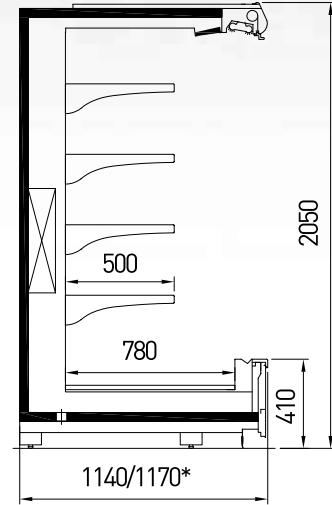

* Double Air Curtain

DRACO D19 PE/SM

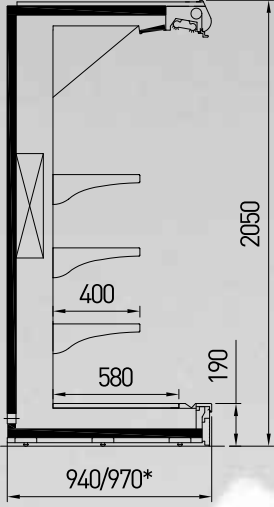

DRACO M19 PE/SM

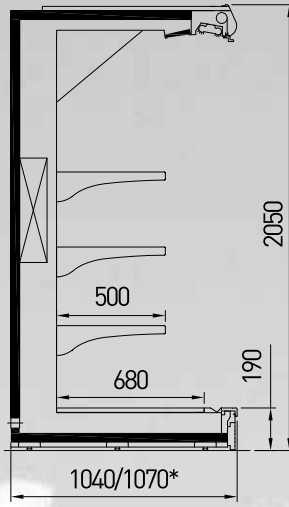

DRACO G19 PE/SM

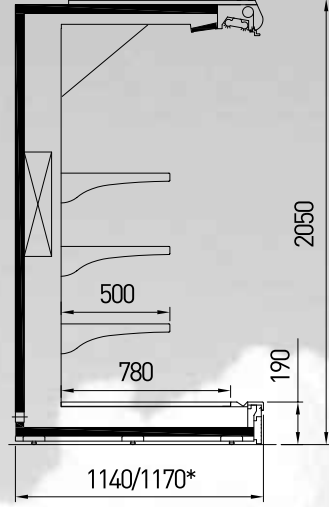

DRACO D29 PE/SM

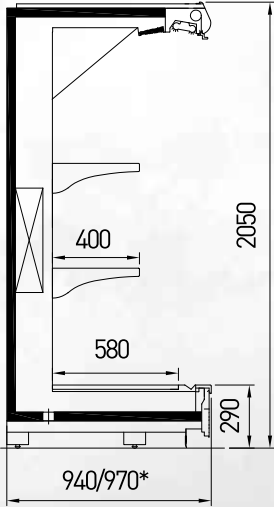

DRACO M29 PE/SM

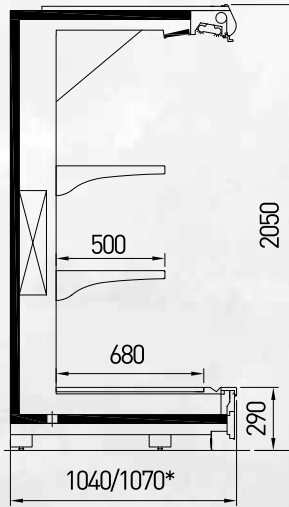

DRACO G29 PE/SM

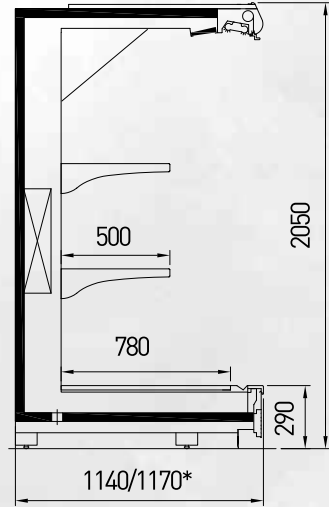

DRACO D41 PE/SM

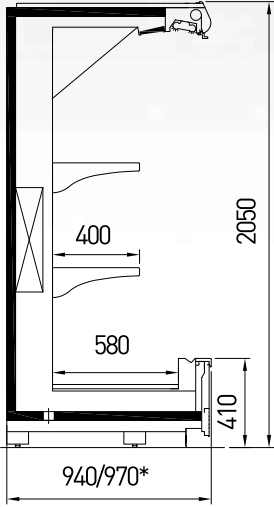

DRACO M41 PE/SM

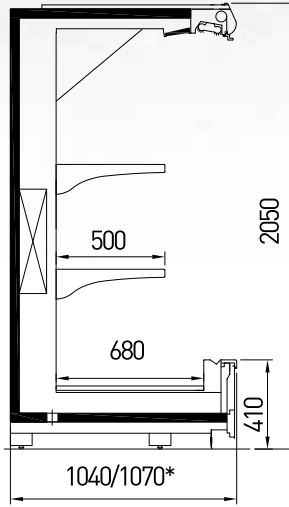

DRACO G41 PE/SM

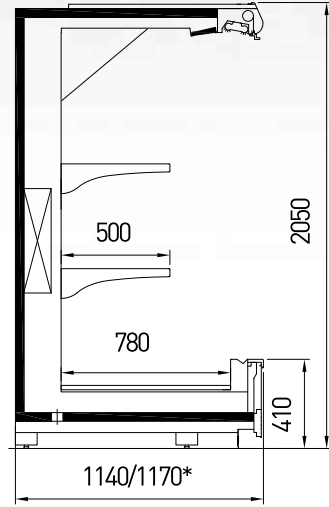

* Double Air Curtain

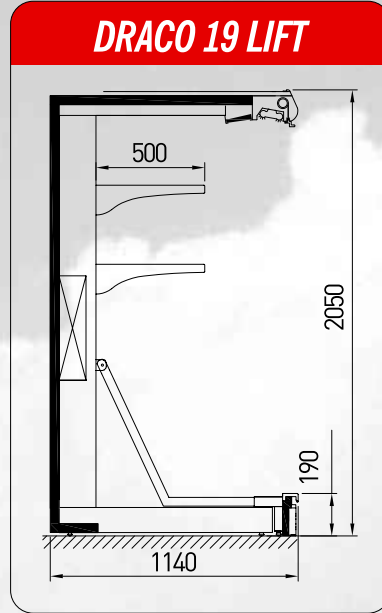
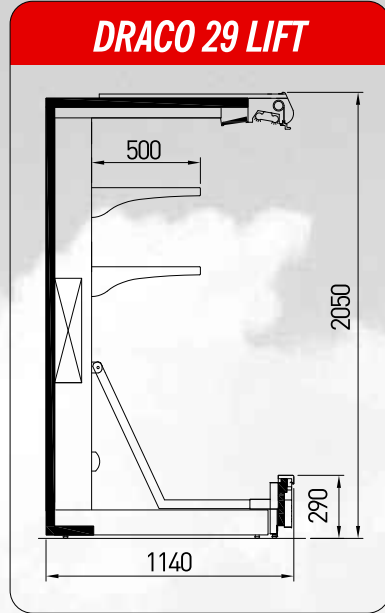

DRACO	Temperature	Length (mm)						
		1250	1875	2500	3750	2000 Head	2300 Head	2600 Head
D19 / D29 / D41 SL	M2 (-1 / +7°C)	◆	◆	◆	◆	◆	◆	◆
M19 / M29 / M41 SL	M2 (-1 / +7°C)	◆	◆	◆	◆		◆	◆
G19 / G29 / G41 SL	M2 (-1 / +7°C)	◆	◆	◆	◆			◆
D19 / D29 / D41 PE	M0 (-1 / +4°C); M1 (-1 / +5°C)	◆	◆	◆	◆	◆	◆	◆
M19 / M29 / M41 PE	M0 (-1 / +4°C); M1 (-1 / +5°C)	◆	◆	◆	◆		◆	◆
G19 / G29 / G41 PE	M0 (-1 / +4°C); M1 (-1 / +5°C)	◆	◆	◆	◆			◆
D19 / D29 / D41 SM	H1 (+1 / +10°C)	◆	◆	◆	◆	◆	◆	◆
M19 / M29 / M41 SM	H1 (+1 / +10°C)	◆	◆	◆	◆		◆	◆
G19 / G29 / G41 SM	H1 (+1 / +10°C)	◆	◆	◆	◆			◆
LIFT	M2 (-1 / +7°C)	◆	◆	◆	◆			◆
Side wall thickness (mm)		40						